

DLRO-H200

Micro-ohmmeter



- **Up to 220 A**
- **Battery supplied**
- **Lightweight – 1 kg**
- **Safe test – DualGround™**
- **Auto range: 1 μΩ to 1000 mΩ**
- **Bluetooth® PC communication**
- **Complies with IEEE and IEC standards**

DESCRIPTION

The DLRO-H200 is designed to measure the resistance of circuit breaker contacts, bus-bar joints and other high-current links. This product is designed with safety, ease of use and versatility in mind.

The micro-ohmmeter can be used anywhere to measure a low resistance value with high accuracy.

DLRO-H200 uses an ultra capacitor to generate the high output current. The ultra capacitor is able to store a huge amount of energy compared to conventional capacitors and can deliver very high current during the discharge thanks to its very low internal resistance.

While testing, the capacitor is discharged through the test object and the voltage drop across- and the current flow through the test object are continuously and synchronously sampled. The resistances calculated from the individual samples are then averaged to obtain the final value.

With DLRO-H200 it is possible to make measurements according to the DualGround™ method. This means that the test object will be grounded on both sides throughout the test giving a safer, faster and easier workflow.

The ruggedness and lightweight makes DLRO-H200 a handheld instrument very suitable for field work, such as in substations. The unit comes with a strong rubber holster accessory which makes it extra durable. DLRO-H200 is dimensioned to make a full day's work of testing without recharge. It can store 104 test values and transfer test data to a PC via Bluetooth.

APPLICATIONS

DLRO-H200 test system is designed to serve a number of applications. The most common are contact resistance measurements of low-, medium- and high-voltage breakers and also at bus-bar joints, and other high current links.

If the contact resistance is too high this will lead to power loss and temperature rise, which often leads to serious trouble. To avoid such problems, it is necessary to check the resistance at regular intervals.

The following table demonstrates how important low resistance is at high currents:

Current	Contact resistance	Power loss
10 kA	1 mΩ	100 kW
10 kA	0.1 mΩ	10 kW
1 kA	1 mΩ	1 kW
1 kA	0.1 mΩ	100 W

At 10 kA a contact with the resistance 0.1 mΩ gives a power loss of 10 kW. This power loss in one single point will definitely confer a temperature rise, which may result in overheating and possibly premature failure.

FEATURES AND BENEFITS

1. Current output terminal (-)
2. Current output terminal (+)
3. Display
The display offers a combination of analogue arc and a dual digital readout:
 - Analogue arc:
Indicates level of the capacitor charge.
 - Dual digital display:
Large main digital readout for good visibility of all main measurement results
Second digital display for additional data.
4. Ground (earth) terminal
5. Keys for navigation and to make settings in the display
6. TEST-button
7. Stand-by/Wake up (Press shortly to toggle)
Clear log (Press and hold for 5 seconds)

8. Function selector

OFF		
I nom	0.1 s	Test positions Measurement time with minimum current guarantee
	0.6 s	
	3 s	
I max	0.1 s	Test positions Measurement time with max. charge
	0.6 s	
	3 s	
Setup	Bluetooth	Bluetooth "pair units"
	Clock	<ul style="list-style-type: none"> ▪ Set date and time ▪ Set volume for the internal buzzer ▪ Discharge the DLRO-H200 internal capacitor
	I nom	Minimum current guarantee setting
	LOG	Data log settings
	P/F	Pass/Fail settings
	PC COM	PC communication (dump data to PC)
Presets	1	Test positions
	2	Stored settings
	3	Set from PC SW

9. Connector for the voltage (-) sense lead
10. Connector for the voltage sense (+) lead and the trig function
11. Connector for the battery charger
12. Battery charger indicator

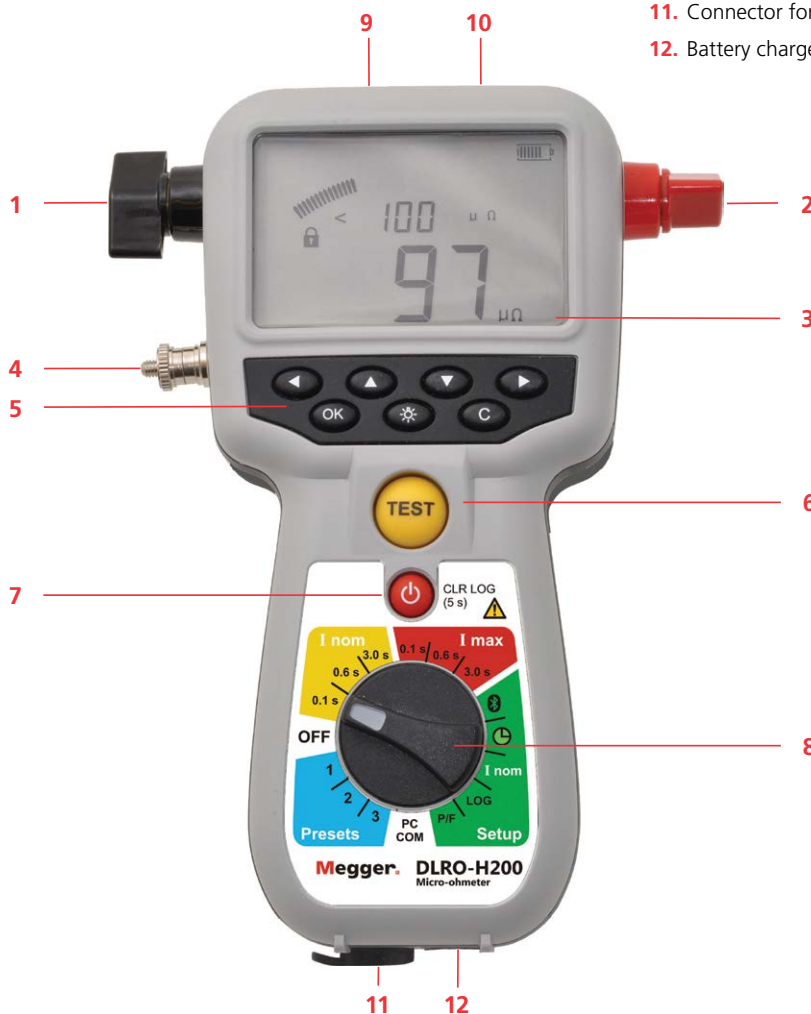

APPLICATION EXAMPLES

Circuit Breaker testing

- Test of circuit breaker contacts
- Test of the connections to the breaker

Testing of Bus-bar

- Test of Bus-bar joints
- Test of connections

**Everywhere you need to test a low resistance/
high current connection**

- Switches
- Disconnecting devices
- Safety ground connections
- Welding points
- Fuses
- Cables



Hold probes / attach Kelvin clamps to CB and press trig / TEST button. A signal indicates whether test was pass or fail and result is logged in unit for later dump to PC.

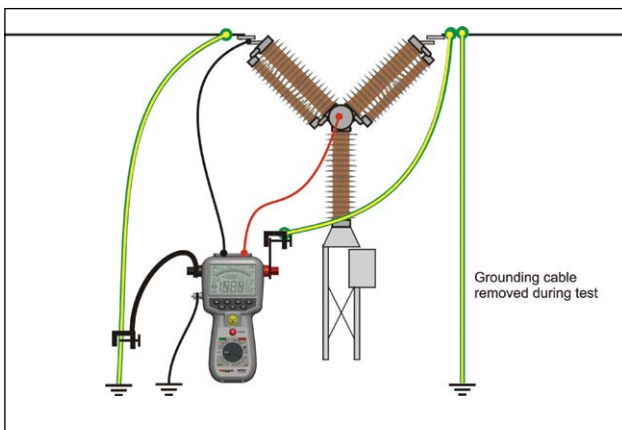

Traditional measurement from ground. Injection is done through existing grounding cable (earthing). Use any of the optional cable kits, GA-00380/82/84, with 5, 10 or 15 m cables.

BOTH SIDES GROUNDED

Many utilities require safety grounds to remain in place during station outages, therefore, the DLRO-H200 was designed with this field safety constraint in mind. DualGround means that the test object will be grounded on both sides throughout the test giving a safer, faster and easier workflow. Minimum time shall be spent in the substation and focus shall be on the test rather than the equipment.

Conventional vs. DualGround	
Site preparation (isolate work area, apply safety ground, issue permit to work)	Site preparation (isolate work area, apply safety ground, issue permit to work)
Hook up test equipment. Issue sanction for test	Hook up test equipment. Issue sanction for test
Authorised person removes the ground	Risky step left out
Perform testing	Safe testing with both sides grounded
Authorised person applies ground	Risky step left out
Cancel sanction for test. Disconnect test equipment	Cancel sanction for test. Disconnect test equipment
Site closing (cancel permit to work, disconnect ground)	Site closing (cancel permit to work, disconnect ground)



Equipment and methods that supports DualGround™ testing are associated with the DualGround symbol. This symbol certifies the use of groundbreaking technology and methods that enables a safe, fast and easy workflow with both sides grounded throughout the test.

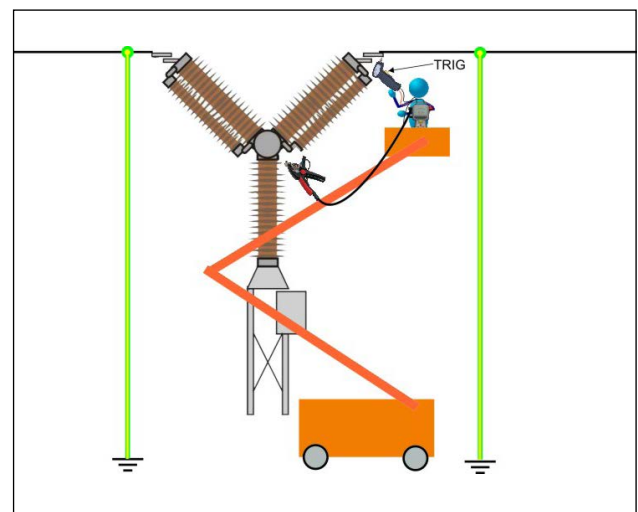

Measurement on CB with both sides grounded, DualGround. Here is a combination of one clamp and one probe used.

4 WIRE KELVIN TEST

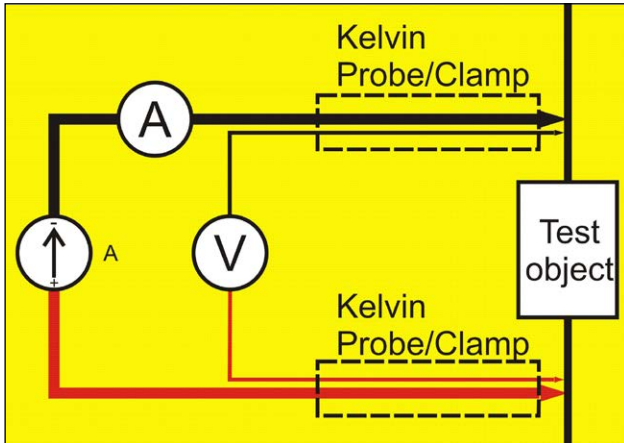

The Kelvin probes (incl. in BD-59090) are used for a 4 wire Kelvin test. This is a way of measuring continuity resistances ensuring all contact and lead resistances are compensated for, which allows a much greater accuracy in measurements. Each Kelvin probe assembly has two probe tips. One tip is for the current generated and the other will measure the very small voltage present.

The Kelvin clamps (incl. in BD-59092) uses the same principle.

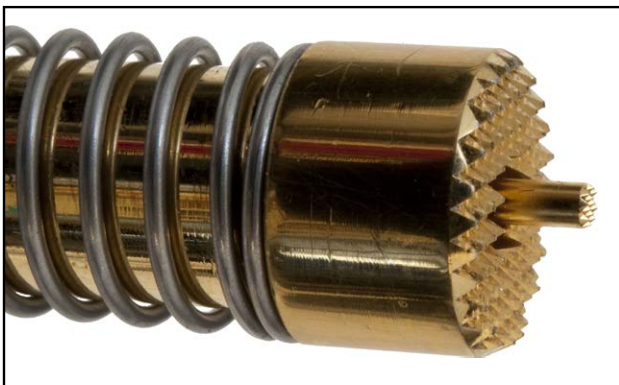

The "double" probe tip showing the springy center tip.



DLRO-H200 (BD-59192) with Transport case, Charger, Kelvin clamps, Rubber holster, Carrying strap, Belt clip, DLRO-H200 Win.

SPECIFICATIONS

Specifications are valid at fully charged batteries and an ambient temperature of +25°C, (77°F). Specifications are subject to change without notice.

Environment

Application field For use in high-voltage substations and industrial environments.

Temperature

Operation -20°C to +50°C (-4°F to +122°F) *)
Storage -40°C to +70°C (-40°F to +158°F)

Relative humidity %RH 5%-95%, non condensing

Pollution degree 2

Shock IEC 60068-2-27

Vibration IEC 60068-2-6

Transport ISTA 2A

*) Battery operation temperature 0°C to +50° (32°F to +122°F)
Battery charging temperature +10°C to +40° (50°F to +104°F)

CE-marking

EMC 2004/108/EC

LVD 2006/95/EC

General

Battery power Five AA (HR6) 2700 mAh NiMH cells

Recharge time < 12 h

Typical recharge time at 25°C 3 h

Battery charger

Mains voltage 100-250 V AC, 50 / 60 Hz

Power consumption 60 W

Protection Against wrong battery type, low/high temperature.

Real time clock battery life ≥10 years

Audible feedback Different buzzer sounds

User presets 3

Field calibration Yes

Encapsulation IP54

Dimensions (excl. binding posts) 217 x 104 x 72 mm
8.5 x 4.1 x 2.8 in.

Weight 1.0 kg (2.2 lbs) instrument only
5.0 kg (11 lbs) with accessories and carrying case

Measurement section

Minimum current guarantee Selectable 50 A / 100 A
Valid at resistance ≤2mΩ

Pass / Fail Settable from 1 μΩ to 1999 mΩ

Number of measurements on fully charged batteries typ. 2200 at I min = 50 A and 0.1 s
typ. 800 at I min = 100 A and 0.1 s

Interference suppression Yes

Range 0 - 1000 mΩ

Range selection Auto

Resolution

0 – 999 μΩ 1 μΩ

1.0 – 9.99 mΩ 0.01 mΩ

10.0 – 99.9 mΩ 0.1 mΩ

100 – 1000 mΩ 1 mΩ

Inaccuracy

0 – 1999 μΩ ±1 % of reading ±1 digit

2 – 1000 mΩ ±2 % of reading ±1 digit

500 – 1000 mΩ ±4 % of reading ±1 digit

Outputs + / -

Range > 100 A DC (R < 2 mΩ)

Output voltage (max) 2.5 V DC

Generation duration Selectable: 0.1 s, 0.6 s, 3 s

Recovery time at I min set to 100 A and load 100 μΩ

Generation time	Max	Typ
0.1 s	10 s	8 s
0.6 s	20 s	16 s
3 s	130 s	100 s

Inputs

SENSE + / -

Connector 4 mm banana jack

Voltage ±3 V DC

Trigger input Threshold 8 V DC

DC IN 12 – 24 V DC, 2 A max

Logger

Logger, Data Label. Timestamp, I max, I min, I Limit, Resistance, Meas.time, P/F limit

Labeling schemes Circuit breaker oriented or running numbers

Capacity 104 measurements

Wireless communication

Headset Bluetooth

PC communication Bluetooth

ACCESSORIES



Test cables with Kelvin probes (incl. in BD-59090)



Test cables with Kelvin clamps (incl. in BD-59092)

OPTIONAL ACCESSORIES



Calibration kit



Bluetooth headset



Bluetooth dongle

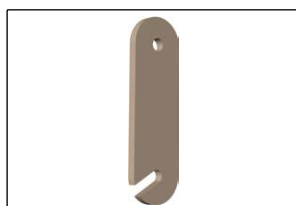

Connection plate, used together with the cable kits.



Soft carrying case

ORDERING INFORMATION

Item	Art. No.
DLRO-H200 Incl. Charger, DLRO-H200 Win	BD-59100
DLRO-H200 Incl. 2 x 1.3 m (4 ft) test cables with Kelvin probes (one with trig button) Transport case, Charger, Rubber holster, Carrying strap, Belt clip, DLRO-H200 Win	BD-59190
DLRO-H200 Incl. 1.3 m (4 ft) test cable red with Kelvin clamp 3 m (10 ft) test cable black with Kelvin clamp Transport case, Charger, Rubber holster, Carrying strap, Belt clip, DLRO-H200 Win	BD-59192
DLRO-H200 Incl. 1.3 m (4 ft) test cable red with Kelvin clamp 5 m (16 ft) test cable black with Kelvin clamp Transport case, Charger, Rubber holster, Carrying strap, Belt clip, DLRO-H200 Win	BD-59193
Optional accessories	
Test cables with Kelvin probes (current & sense) 2 x 1.3 (4 ft) m (one with trig button)	GA-90000
Test cables with Kelvin clamps (current & sense) 1.3 m (4 ft) red, 3 m (10 ft) black	GA-90001
Current cable with Kelvin clamp 3 m (10 ft) black, 16 mm ²	GA-00372
Current cable with Kelvin clamp 1.3 m (4 ft) red, 16 mm ²	GA-00373
Current cable with Kelvin clamp 5 m (16 ft) black, 25 mm ²	GA-00374
Current cable with Kelvin clamp 10 m (33 ft) black, 16 mm ²	GA-00376
Cable kit 5 m (for use with the std. ground connectors) Current cable 0.5 m (1.6 ft), Connection plate and sense cables 5 m (16 ft), Ground cable	GA-00380
Cable kit 10 m Current cable 0.5 m (1.6 ft), Connection plate and sense cables 10 m (33 ft), Ground cable	GA-00382
Cable kit 15 m Current cable 0.5 m (1.6 ft), Connection plate and sense cables 15 m (49 ft), Ground cable	GA-00384
Bluetooth kit Bluetooth headset and dongle for PC	XC-06000
Calibration kit	BD-90002
Soft carrying case For DLRO-H200, Charger and Cables	GD-00620